



SP-6/ SP-2000/ SP-220/ SP-7000 SUPER AMP GaAsFET SERIES 50, 144, 220 & 432/435 MHz. Mast-Mounted Preamplifiers

Thank you for purchasing this preamplifier which is manufactured by SSB ELECTRONIC GmbH. We believe that it is without a doubt the best available anywhere and would ask that you please spend a few moments to read through these notes in order to ensure that you obtain the very best possible results from this product.

The full potential of this preamplifier can only be realized when a minimum of feed line exists between the preamplifier input and the antenna feed point. Maximum lengths are: 24 ft. on 50/144MHz and 15 ft. on 432MHz assuming that a quality coax. such as AIRCOM PLUS is used. This length can usually be achieved by mounting the preamplifier on the support mast close to the antenna mounting point.

The amplification factor of this preamplifier can be adjusted so that a good system gain distribution can be maintained. This is important in order to insure that the receiver front-end as well as the mixer are not overloaded. The following table may be used as a guide for setting the preamplifier gain to overcome the feedline losses encountered from your rig to the preamp.

<u>CABLE LOSSES</u>	<u>GAIN SETTING</u>
Under 2 dB	MIN
2 - 3 dB	MID
Over 3 dB	MAX

The following table may be used as a guide to the losses for various cable types:

<u>Frequency</u>	<u>RG58U</u>	<u>RG213</u>	<u>AIRCOM PLUS</u>
144 MHz.	0.2 dB/M	0.08 dB/m	0.05 dB/M
432 MHz	0.4 dB/M	0.15 dB/m	0.08 dB/M

A good rule of thumb is to aim for 12 - 14 dB. of gain above feed line losses.

Access to the gain adjusting potentiometer is obtained by removing the four self tapping screws from the underside of the unit. This enables the plastic weather shield to be removed exposing the tin plated shielded box in which a small hole will be found. Adjustment may now be made with a small screwdriver. CAUTION: Great care should be taken when making this adjustment noting:

- The potentiometer only rotates through 270 deg.
- Do not exert any pressure on the adjuster
- Ensure the screwdriver goes to the pot, and does not slip sideways causing possible damage to any surrounding components. An insulated trimming tool would be best suited for this job!

If the tin plate box lid is removed to make this adjustment then please **DO NOT TOUCH ANY OTHER CONTROLS** as these have all been carefully set at the factory for the best noise figure.

The Super Amp. has a built in RF SWITCHING (Vox) capability. This makes for an extremely simple installation. However, it is important that the following maximum power limits are not exceeded in order to prevent damage to the GaAsFET and possible burning of the relay contacts.

THE MAXIMUM RF VOX SWITCHED POWER IS:

<u>50MHz</u>	<u>144 MHz</u>	<u>220MHz.</u>	<u>432 MHz</u>
150Watts	200 Watts	100 Watts	100 Watts

Provided these levels are not exceeded the preamp may be connected as shown in Fig. 1

FIGURE 1

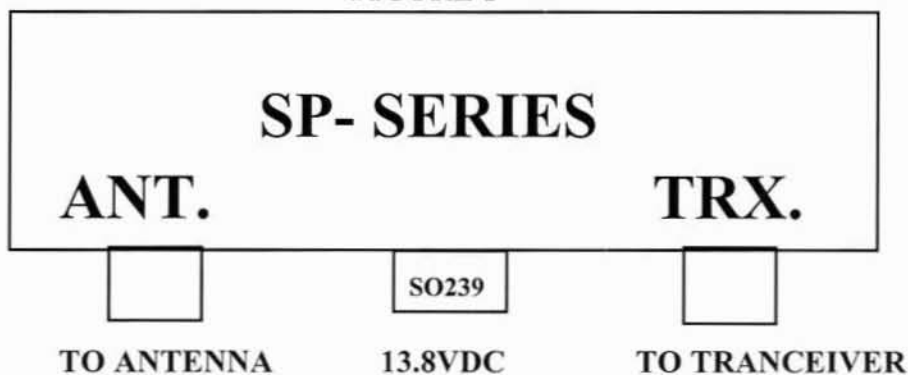

+13.8V should be connected to the SO239 connector that is located between the "N" female connectors. The center pin of the SO239 is positive and the outer shell is negative. If you choose to utilize your preamp in an RF Sensed environment as illustrated in figure 1, voltage may be left on to the preamp at all times.

Some of the newer radios can provide a switched preamp control voltage via the feedline. If your radio provides this feature, you may hookup your preamp as illustrated in Figure 1. It will not be necessary to provide 13.8VDC via the SO239 connector, since your radio will provide this function.

If higher power levels are to be used then it is imperative to use the DCW-15B sequenced controller. Figure 2 and Figure 3 illustrates this arrangement.

FIGURE 2

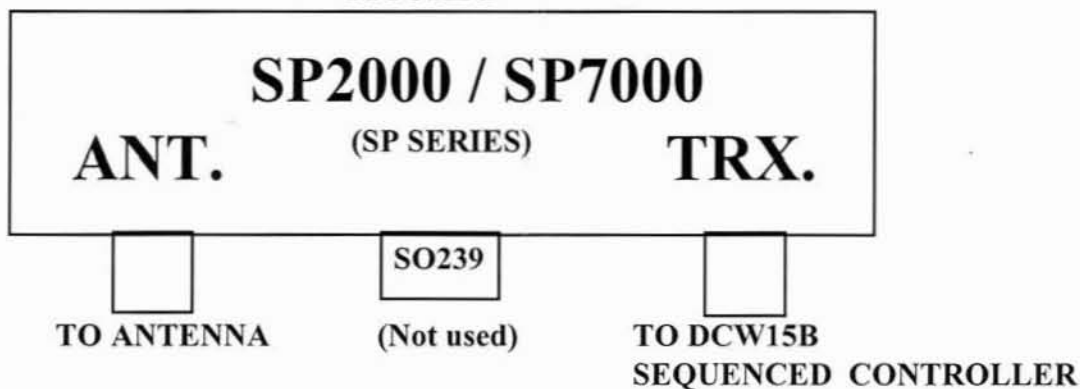

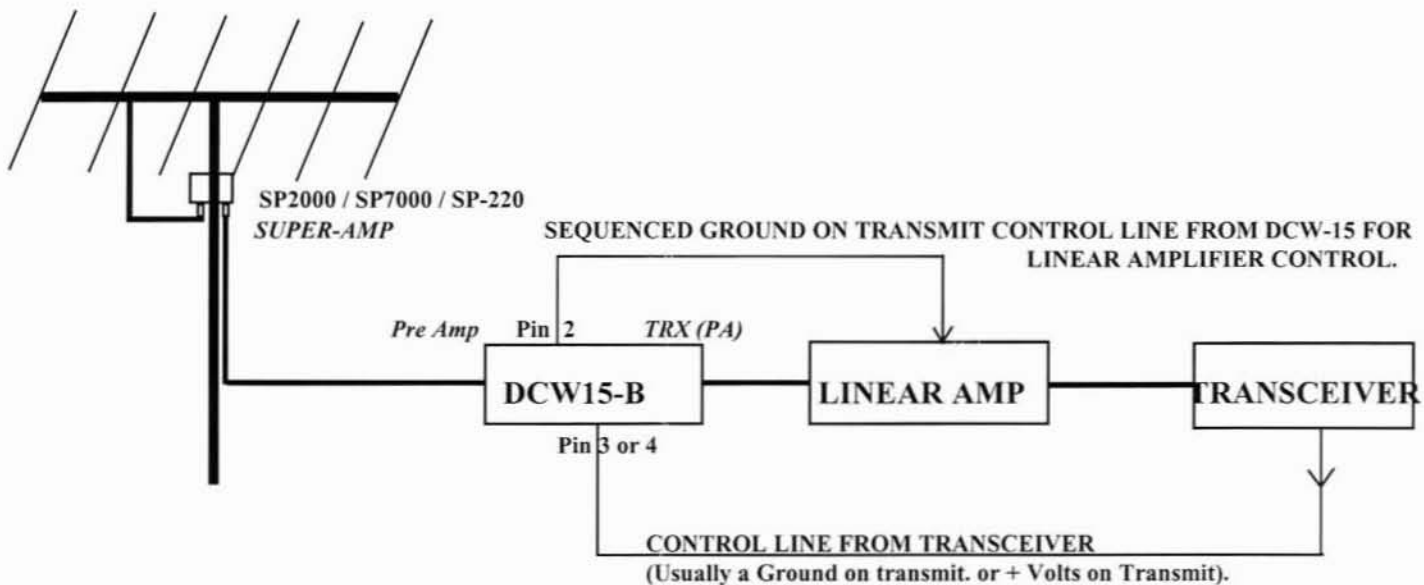

FIGURE 3

SP-2000, SP-7000, SP-6, SP-220 HIGH POWER HOOK-UP

By utilizing our DCW-15B Sequenced Controller, the SP SERIES of Pre-amplifiers can be safely used in a high power environment. The maximum sequenced power levels are:

<u>50MHz.</u>	<u>144MHz</u>	<u>220MHz.</u>	<u>432MHz</u>	
650Watts	750 Watts	650 Watts	500 Watts	CW/SSB
			150 Watts	ATV

The DCW-15B SEQUENCER provides sequenced control of your Linear Power amplifier. It guarantees that preamplifier switchover occurs prior to linear amplifier turn-on. The DCW15-B insures that hot-switching of the coaxial relays at elevated power levels will not take place. The DCW-15B has a built in low loss BIAS "T" that provides the preamplifier control voltage via the feedline thus eliminating the additional expense of another cable. In addition, the DCW15-B allows front panel switch selection of Linear amplifier In/Out and Preamplifier In/Out functions.

DCW-15 B D-Sub Connector Pin-outs

<i>Pin 1</i> Ground	Ground
<i>Pin 2</i> PA Control	Provides a sequenced ground on transmit via a relay contact to control Linear Amplifier turn on. This function is bypassed when Linear amplifier <i>OUT</i> has been selected via the front panel.
<i>Pin 3</i> PTT Line 1	Grounding this line starts sequencer functions. If your rig provides a ground on transmit via a PTT jack, connect your rig's PTT line to PIN 3.

