

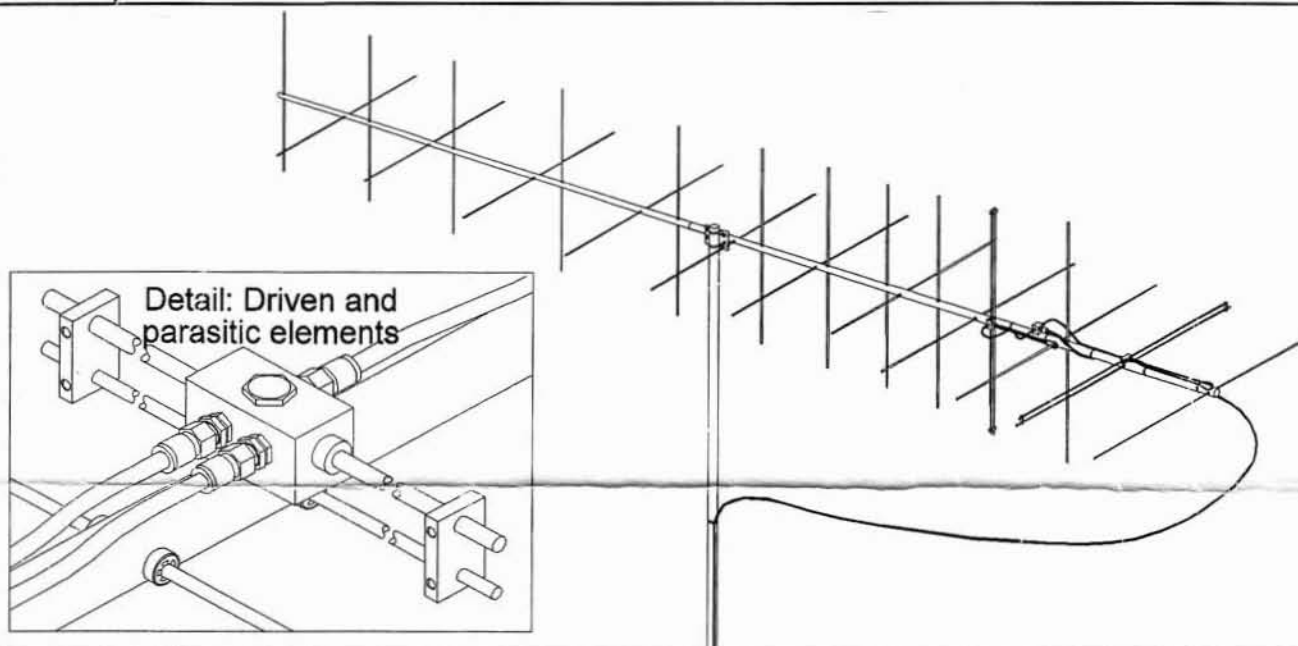

2MCP22 Circular Polarized Antenna



SPECIFICATIONS

Model Number.....	2MCP22
Frequency Range.....	144 TO 148 MHz
Gain @ 145.9 MHz.....	12.25 dBdc
Beamwidth.....	38 degrees
Polarity.....	Circular RHC OR LHC
Front To Back.....	25 dB Typical
VSWR.....	1.4: Max
Feed Impedance.....	50 Ohms Unbal.
Connector.....	'N' Female
Power Handling.....	1.5 KW
Stacking Distance.....	9.5 to 10 feet
Turning radius.....	10 ft.
Boom Length.....	18' 7"
Boom Diameter.....	1-1/2, Tapering to 1"
Elements / type.....	22 / 3/16" Alum Rod
Wind Area.....	2.5 sq. ft.
Weight/ ShipWt.....	12.5 lbs 14 lbs UPS

FEATURES

This cross polarized yagi was computer designed for the serious OSCAR user. The average side and back lobes power have been reduced by approximately 10 dB over any previous design, enhancing signal to noise ratio and putting all your power where it will do the most good. The 2MCP22 is ideal for general use over the ENTIRE two meter band from FM to SSB and CW DX. Arrays of two or more will even permit moonbounce contacts using the old reliable passive repeater in the sky.

The unique Driven Element Modules are CNC machined and feature O-ring sealed connectors. Internal connections are encapsulated in a space age silicone gel with nearly 4 times the dielectric strength of air. The 2MCP22 is our finest circular polarized antenna. We are confident you will be impressed with the 2MCP22 from the moment you open the box until you've worked DXCC and beyond!

Optional items include HDFG fiberglass crossboom kit compatible with Yaesu 5400 and 5600 series az-el rotators, power dividers 2M2PORT and 2M4PORT, phasing lines VHF-50-2MCP22(2) or (4), 'H' frames, OR-2800 az and MT-1000 and MT3000 el rotators.

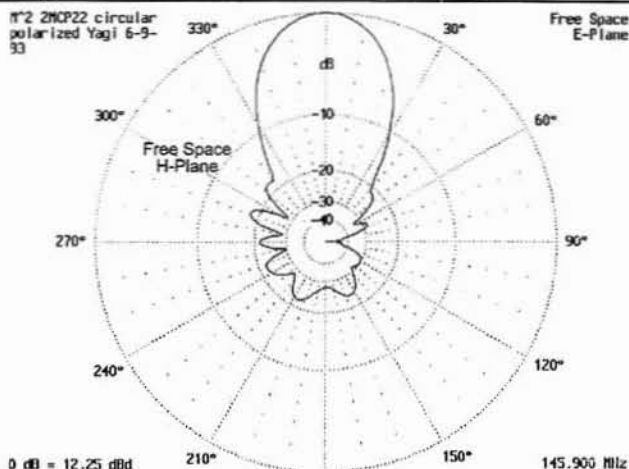

2MCP22 DIMENSIONS

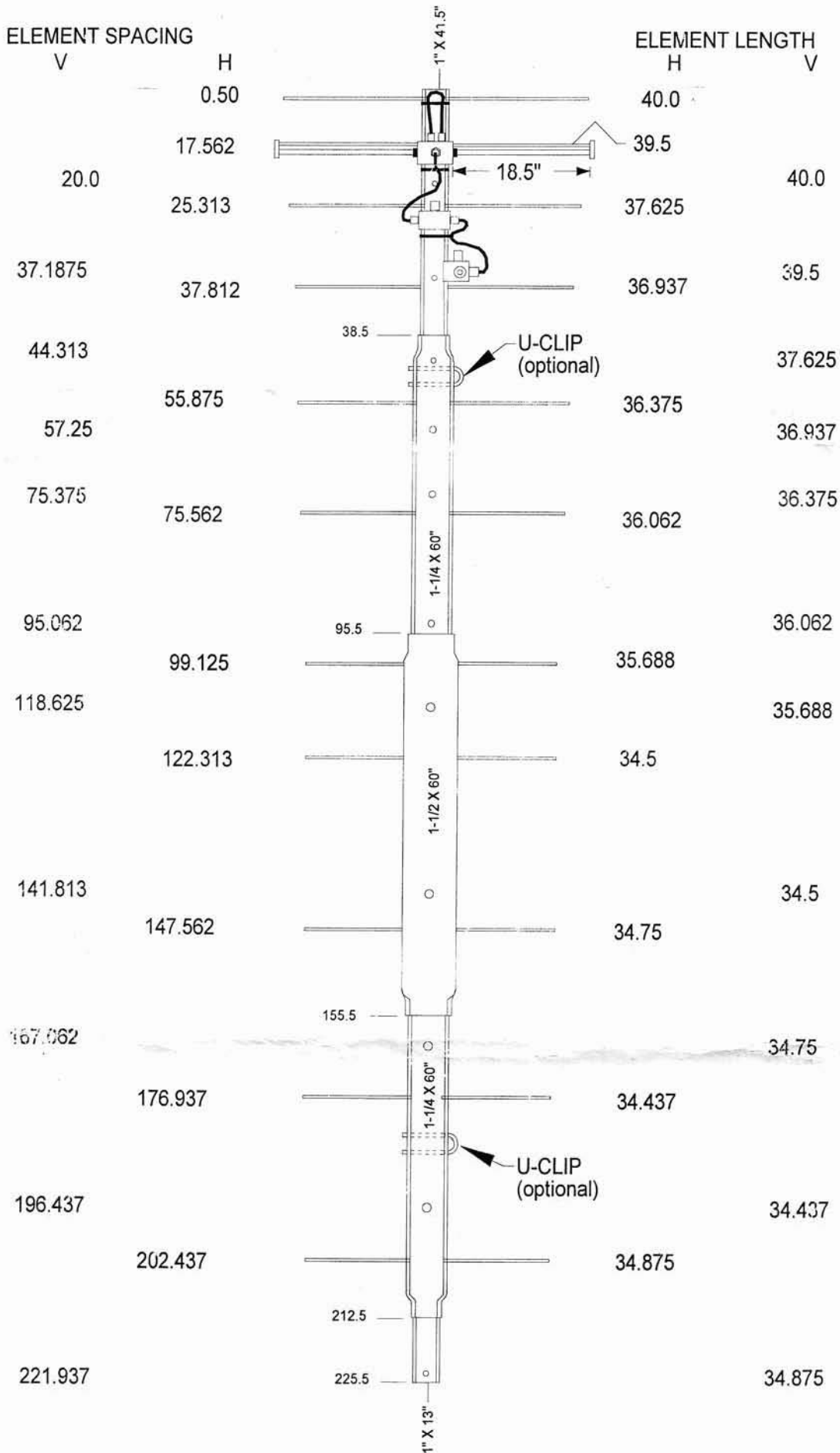

DECIMAL TO FRACTION CONVERSION

- .062 = 1/16"
- .125 = 1/8"
- .188 = 3/16"
- .250 = 1/4"
- .313 = 5/16"
- .375 = 3/8"
- .437 = 7/16"
- .50 = 1/2"
- .562 = 9/16"
- .625 = 5/8"
- .688 = 11/16"
- .75 = 3/4"
- .813 = 13/16"
- .875 = 7/8"
- .937 = 15/16"
- 1.0 = 1"

TOOL REQUIRED FOR ASSEMBLY: screwdriver, 11/32 nut driver or wrench, 7/16" and 1/2" end wrenches, pliers, measuring tape.

1. Start by laying out the boom sections, noting hole positions and matching to the DIMENSION SHEET. Use 8-32 X 1-1/2" screws and locknuts to join 1" to 1-1/4" sections; 1-3/4" screws for 1-1/4" to 1-1/2" sections.

2. Separate elements by length into two identical sets, "H" and "V." Position the "H" element set along the boom by "H" length and position as shown the DIMENSION sheet. Start with the reflector (longest) element. Balance it on your finger to find rough center and push on a black button insulator to about 1/2" off center. Push the element through the holes 1/2" from the rear of the boom and install the second button, snugging it up into boom. **DO NOT BOTHER CENTERING** the element at this time and **DO NOT INSTALL** the stainless steel shaft retainers yet. It is easier to do after all the horizontal elements are installed in the boom.

3. Install the 3/16" rod DRIVEN ELEMENT as you did the reflector. Then continue with the installation of the DIRECTORS. **Note that the Director Elements do not consistently diminish in length from rear to front, so pay close attention to length and position.**

4. Now begin centering the elements. Use a tape measure to EQUALIZE the amount the element sticking out on each side of the boom. Once you have all the elements centered, sight down the element tips from the rear comparing each side. Look for any obvious discrepancies and correct if found.

5. NOTE: The SHAFT RETAINERS, for securing the elements, should always be used for permanent and long term antenna installations. For portable or temporary use, or whenever it is anticipated that the antenna will be disassembled within a short time, the retainers may be left off. The button insulators, normally a tight fit, (if not deform the hole slightly with pliers) hold the elements quite securely.

To install the stainless steel SHAFT RETAINERS, use thumb and forefinger to hold the retainer over the end of the PUSH TUBE (3/8" x 3" tube, supplied in the kit), internal fingers on retainer dished into tube. HOLD THE ELEMENT FIRMLY TO PREVENT IT FROM SLIDING OFF CENTER and press the retainer onto the element end and continue until retainer butts on insulator button. Locking pliers, *lightly* clamped up against opposite button insulator will help maintain center reference. If you push the first retainer too far, remove element from boom, push retainer completely off the element, and start over. Install another retainer to the opposite side of the element. Continue installing retainers until all elements are locked in place.

6. Mount the HORIZONTAL DRIVEN ELEMENT BLOCK / ROD ASSEMBLY to the TOP of the boom using a single 8-32 X 1-1/4" screw. Orient the block with the two balun connectors facing to rear. Install the 8-32 x 1/4" set screws (internal Allen head - tool supplied) into the SHORTING BARS. Slide one bar onto each end of the Driven Element Block Rods and the 3/16" dia. driven element rod. Position the Shorting Bars to the dimension shown on the DIMENSION SHEET. The bars will tilt slightly based on the position of the two element rods. Align the bars with each other and tighten the set screws.

7. Mount the "T" JUNCTION BLOCK on the top of the boom to holes about 9" to the rear of the vertical driven element block. Orient "N" feed connector to the rear. Secure with 8-32 x 1-1/4 screw.

8. ASSEMBLING THE VERTICAL ELEMENTS

Repeat steps #2 through #5 for the Vertical elements, using the Dimension Sheet as your guide to lengths and spacing.

